

# Winlet 400

TL

DHB

HS

Off-road model with great stability, extra reach and a front with horizontal hydraulic side shift.

*i* MAX LIFTING HEIGHT 3.465 MM

*i* WIDTH 860 MM

*i* MAX LIFTING CAPACITY 415 KG

*i* HYDRAULIC SIDESHIFT 100 MM

Are you looking for an off-road glazing robot with extra lifting height and an impressive lifting capacity? This is it!

Winlet 400TL is built to operate in an outdoor terrain and is extremely stable.



Winlet 400TL is equipped with extra wide steering and traction wheels making it extremely stable and ideal for outdoor installations.

## KEY ADVANTAGES

- Powerful front wheel drive
- Electromagnetic brakes
- Integrated safe & reliable 2 circuit vacuum system
- Ecomatic battery saving system
- Intelligent overload monitoring system
- Easy maneuvering with ergonomic operating lever
- 100% linear movements of the front
- Hydraulic linear movements controlled at the front
- Integrated lifting point for lifting the Winlet by crane
- 6 integrated lashing fittings for safe transport
- Weather resistant design

www.vanbouwel-kranen.be



Energielaan 2-4  
B-2950 Kapellen  
+32 (0)3 666 33 33



## CHOOSE BETWEEN MAC OR PSAC CONTROL



All Winlet 400 configurations are available with one of two different operating panels.

Choose which one fits your needs.

**1. MAC (Multi Axis Control)**, which allows controlling of more hydraulic functions at a time. The operator can adjust the speed at the levels: 100 % - 50 % - 10 %.

**2. PSAC (Proportional Single Axis Control)**, the traditional Winlet controls, where one function is operated stepless.

# Winlet 400TL DHB/HS

## TECHNICAL SPECIFICATIONS\*

LIFTING CAPACITY	415 KG	TILT FUNCTION	BACK: 43° FORTH: 98°
MAX LOAD ARM OUT/IN	130 KG / 415 KG	ROTATION	2 X 180 DEGREES
MAX SIDE MOUNTED LOAD	200 KG	SUCTION CUPS	4 X Ø310 (Ø360 / Ø410)* MM
TOTAL LENGTH	1.950 MM	FRONT WHEEL DRIVE	1200W
TOTAL WIDTH	860 MM	24v AC transaxle	
Single mounted tires		BATTERIES	2X90 AH
TOTAL WEIGHT	905 KG	OPERATING HOURS	12 HOURS
LIFTING HEIGHT	3.100	On fully charged batteries	
Vertical cups, center of lifting yoke		CHARGING TIME	8-10 HOURS
EXTENSION MIN/MAX	450 MM / 1.450 MM	SUITABLE FOR OUTDOOR USE	YES
Front bumper to suction cup		Water resistant	
LIFTING HEIGHT MIN/MAX	0 MM / 1.065 MM	INTEGRATED LIFTING EYE	YES
Horizontal cups down		For lifting of the Winlet	
LIFTING HEIGHT MIN/MAX	2.650 MM / 3.465 MM		
Horizontal cups up			

\*Optional

## WINLET 400TL DHB/HS MAX. LOAD/REACH kg.

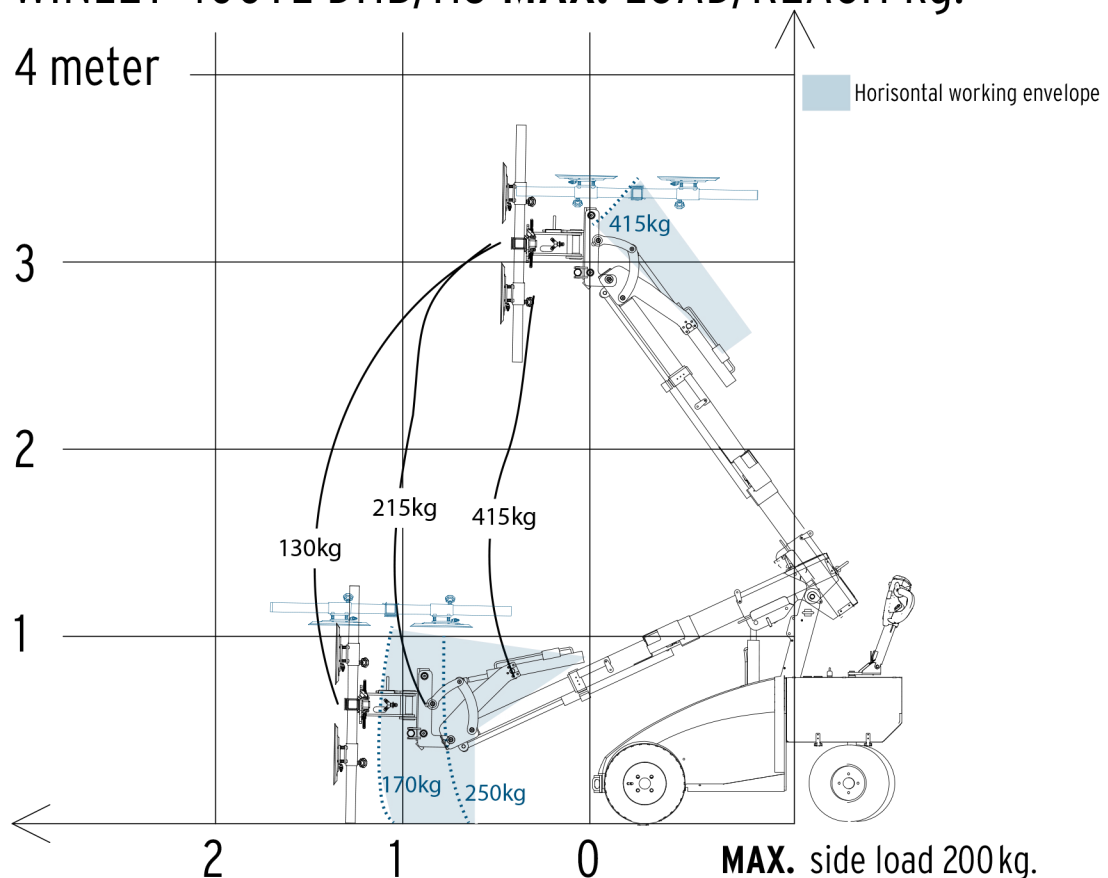

\*The dimensions are indicative and may vary +/- 10mm

# Winlet 400TL DHB/HS

## DIMENSIONS\*

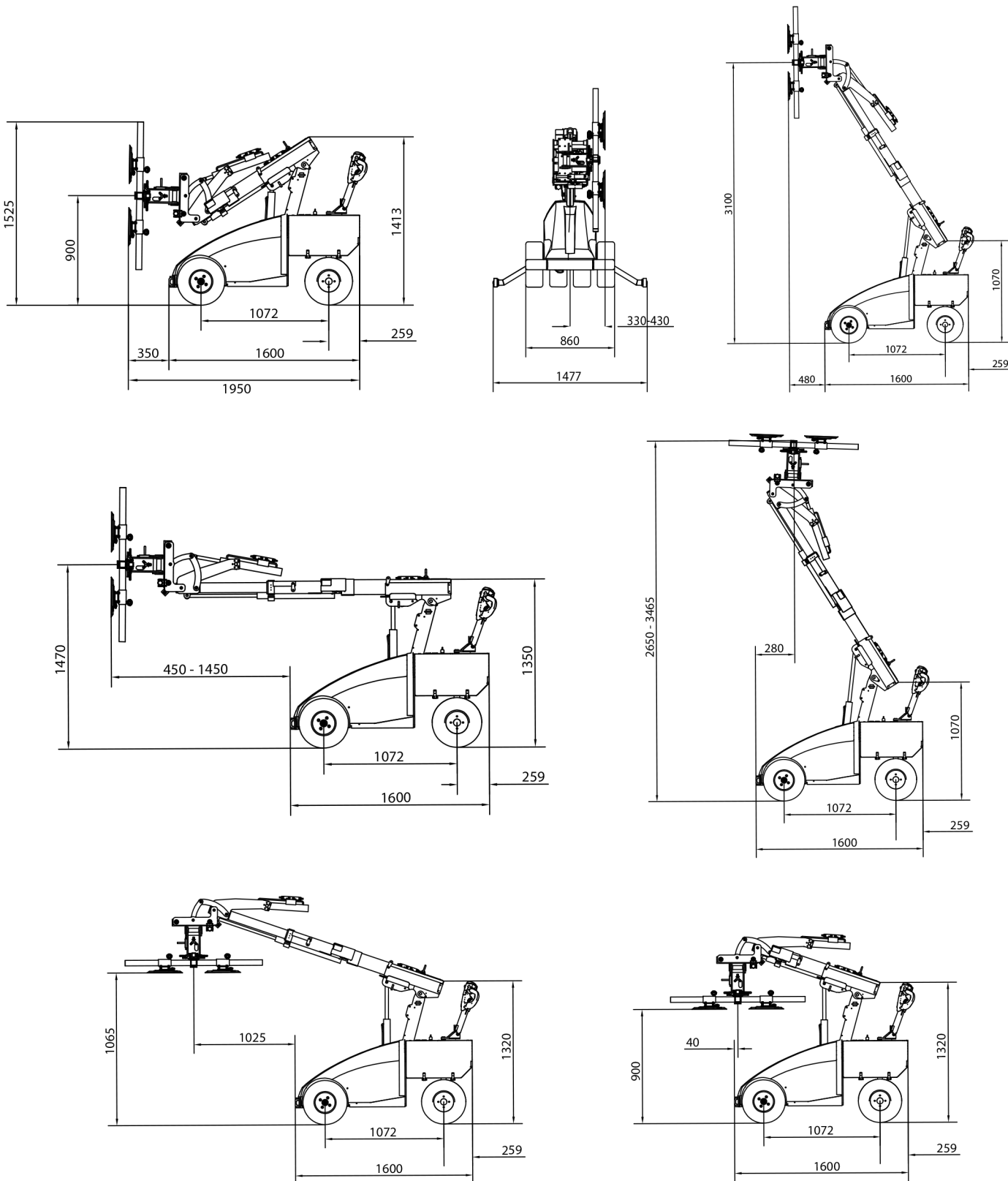

\*The dimensions are indicative and may vary +/- 10mm